

SPECIFICATIONS FOR ROAD GRAVEL

1. DESCRIPTION OF THE WORK

The work covered by these specifications shall include the supplying of all labour, machinery, plant, equipment and materials required to complete in an expeditious and workmanlike manner, all work necessary to supply, screen, haul, weight and stockpile material in accordance with these specifications, and deposit same in the City stockpile at the location designated.

The designated stockpile location is at the Utilities Service Centre, 11th Ave. N.W. and High Street.

2. MATERIALS:

2.1 The soil stabilized gravel base course shall be composed of fragments of durable rock free from undesirable quantities of soft or flaky particles, loam, and organic or other deleterious material. The base aggregate shall not contain clay balls. The determination of undesirable quantities is at the discretion of the City Engineer.

(a) The 2" soil stabilized gravel base course shall comply with the requirements listed below:

<u>Sieve Designation</u>	<u>Percent by Weight Passing</u>
40.0mm	100%
31.5mm	95 - 100%
18.0mm	70 - 90%
5.00mm	35 - 60%
2.00mm	22 - 38%
0.900mm	15 - 25%
0.400mm	10 - 18%
0.071mm	5 - 10%

Plasticity Index -- less than six (6).

2.2 The Contractor shall at its own cost, arrange for the testing of all material by a consultant to be approved by the City.

2.3 All crushed material must first be stockpiled at the gravel pit or at a location other than the City's gravel yard. Stockpiles at the pit may be any size from 500 tonnes upwards. Samples will be taken and tests will be made by the consultant approximately after the first 500 tonnes deposited in the pile and further samples will be taken and tests made by the consultant approximately after each additional 500 tonnes deposited in the pile. Each stockpile will have to be approved in total by the consultant before deliveries can be made to the City's gravel yard. The frequency of testing every 500 tonnes may be adjusted upwards if the pit face is uniform and previous test results consistently meet required specifications.

SPECIFICATIONS FOR ROAD GRAVEL

1. DESCRIPTION OF THE WORK

The work covered by these specifications shall include the supplying of all labour, machinery, plant, equipment and materials required to complete in an expeditious and workmanlike manner, all work necessary to supply, screen, haul, weight and stockpile material in accordance with these specifications, and deposit same in the City stockpile at the location designated.

The designated stockpile location is at the Utilities Service Centre, 11th Ave. N.W. and High Street.

2. MATERIALS:

2.1 The soil stabilized gravel base course shall be composed of fragments of durable rock free from undesirable quantities of soft or flaky particles, loam, and organic or other deleterious material. The base aggregate shall not contain clay balls. The determination of undesirable quantities is at the discretion of the City Engineer.

(a) The 3/4" soil stabilized gravel base course shall comply with the requirements listed below:

<u>Sieve Designation</u>	<u>Percent by Weight Passing</u>
25.0mm	100%
18.0mm	87 - 100%
12.5mm	72 - 93%
5.00mm	45 - 77%
2.00mm	29 - 56%
0.900mm	18 - 39%
0.400mm	13 - 26%
0.160mm	7 - 16%
0.071mm	6 - 11%

Plasticity Index -- less than six (6).

2.2 The Contractor shall at its own cost, arrange for the testing of all material by a consultant to be approved by the City.

2.3 All crushed material must first be stockpiled at the gravel pit or at a location other than the City's gravel yard. Stockpiles at the pit may be any size from 500 tonnes upwards. Samples will be taken and tests will be made by the consultant approximately after the first 500 tonnes deposited in the pile and further samples will be taken and tests made by the consultant approximately after each additional 500 tonnes deposited in the pile. Each stockpile will have to be approved in total by the consultant before deliveries can be made to the City's gravel yard. The frequency of testing every 500 tonnes may be adjusted upwards if the pit face is uniform and previous test results consistently meet required specifications.

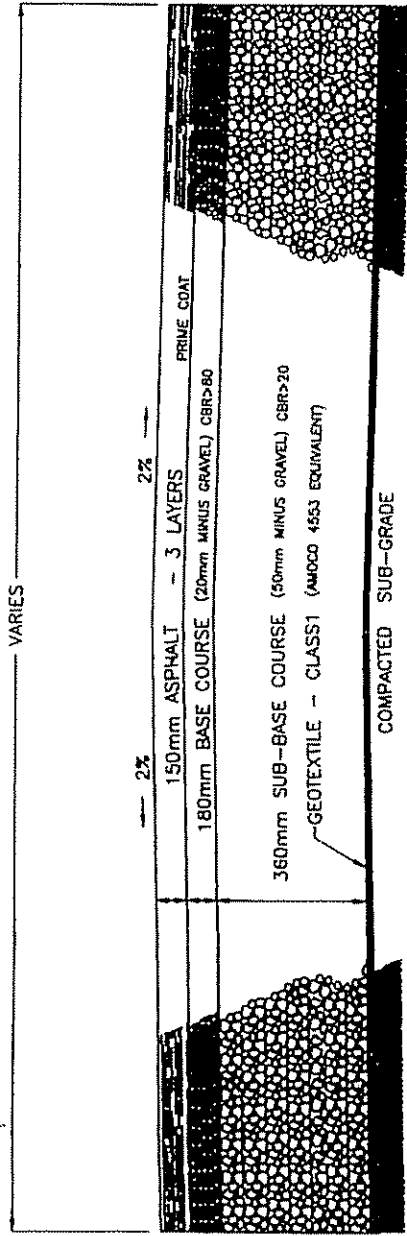

TYPICAL CROSS SECTION

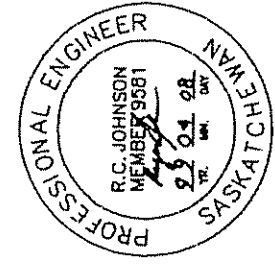

CITY OF MOOSE JAW ENGINEERS DEPARTMENT	
CLASS A-1 ASPHALT ROAD	
DRAWN L.G. HASTINGS	DATE MAR.10 /99
RYAN JOHNSON CITY ENGINEER	SCALE N.T.S.
	DWG. NO. R-1(A1)

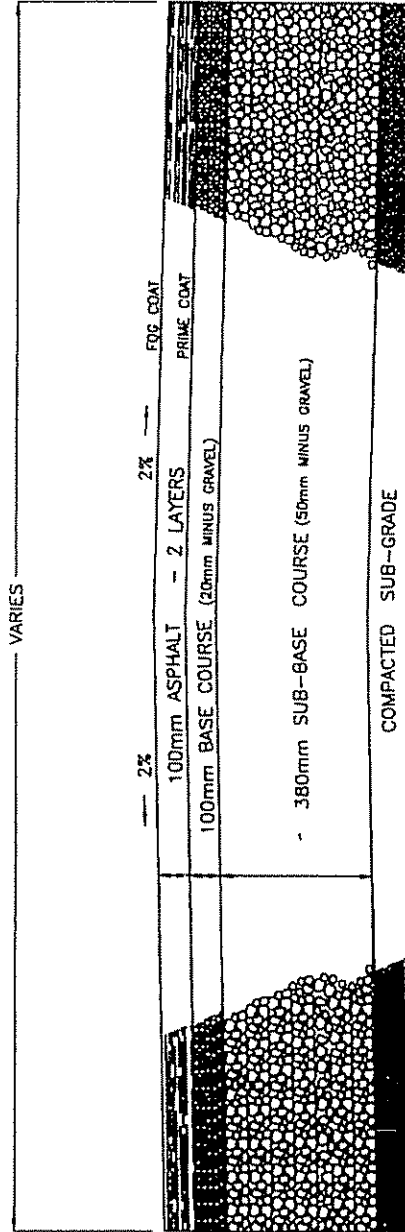

TYPICAL CROSS SECTION

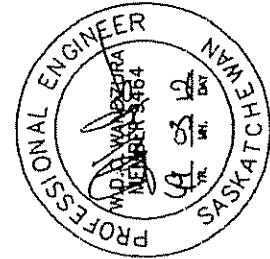

CITY OF MOOSE JAW
ENGINEERS DEPARTMENT

CLASS A
ASPHALT ROAD

DRAWN L.G. SYDIAHA	DATE JUL 20/98	DWG. NO.
M.D.C. WANDZURA CITY ENGINEER		R-1A
SCALE N.T.S.		

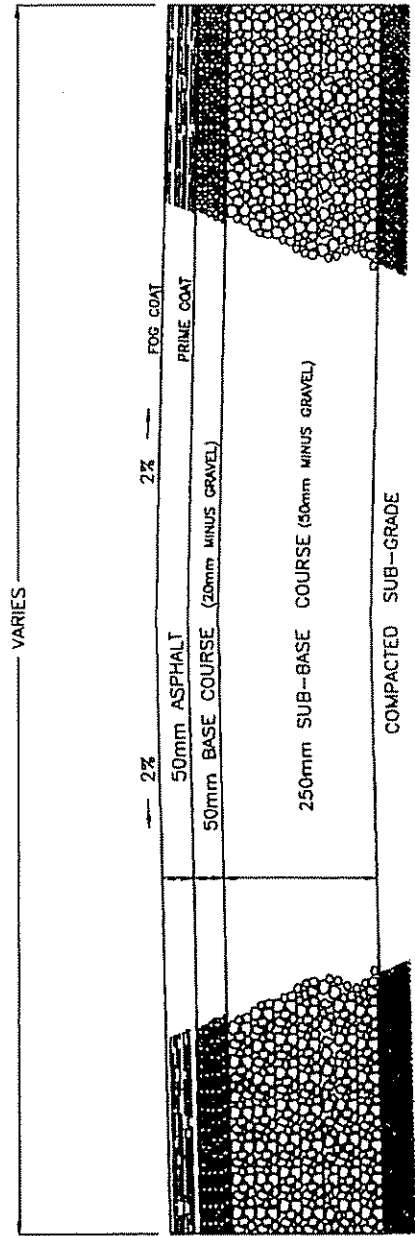

TYPICAL CROSS SECTION

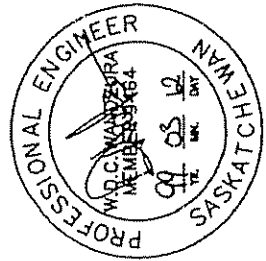

CITY OF MOOSE JAW
ENGINEERS DEPARTMENT

CLASS B
ASPHALT ROAD

DRAWN L.G. SYDIAHA	DATE JUL. 20/98	DWG. NO.
W.D.C. WANDZURA CITY ENGINEER	SCALE N.T.S.	R-1B

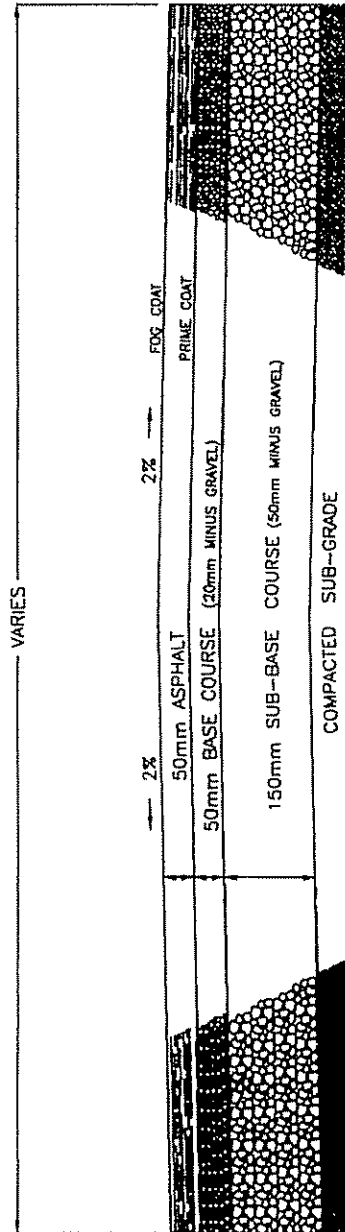

TYPICAL CROSS SECTION

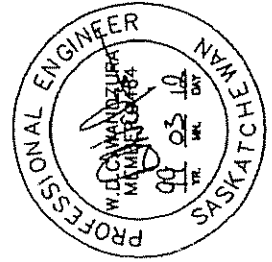

CITY OF MOOSE JAW
ENGINEERS DEPARTMENT

CLASS C
ASPHALT ROAD

DRAWN L.G. SYDIAHA	DATE JUL 20/98	DWG. NO.
A.J. SCHWINGHAMER CITY ENGINEER	SCALE N.T.S.	R-1C

EQUIVALENT TRAFFIC WIDTH	FOR INTERNAL CURB & GUTTER	FOR SEPARATE CURB & GUTTER
8.7m		
11.0m	NOT APPLICABLE	
13.4m		
14.8m		
2 x 7.9m		
2 x 11.7m		

CROSS SECTIONS

NOTES:

1. CROSS SECTIONS GIVEN ABOVE ARE BASED ON ESTABLISHED CONSTRUCTION PRACTICES. VARIATIONS IN THE WIDTHS OF POURS THAT ACHIEVE THE DESIRED TRAFFIC WIDTHS ARE SUBJECT TO THE APPROVAL OF THE CITY ENGINEER
2. MINIMUM CROSS SLOPE 2.5%
3. ALL DIMENSIONS ARE IN MILLIMETRES UNLESS OTHERWISE NOTED. DIMENSIONS IN PARENTHESIS ARE IN IMPERIAL UNITS.

CITY OF MOOSE JAW
ENGINEERS DEPARTMENT

TYPICAL CROSS SECTIONS
FOR PORTLAND CEMENT
CONCRETE PAVEMENTS

DRAWN N/A	DATE MAR. / 08	DWG. NO.
R. JOHNSON CITY ENGINEER	SCALE N.T.S.	R-2A

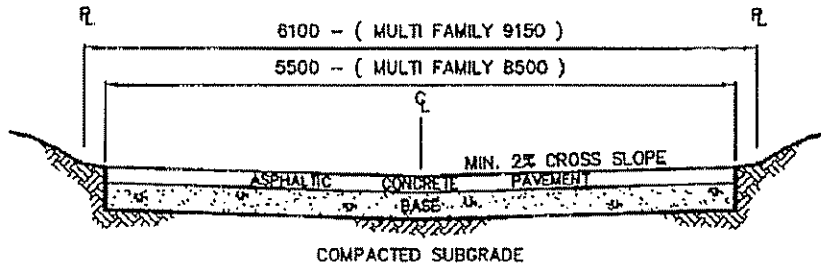

- PAVEMENT STRUCTURES**
- | | | | | |
|--------------------------------|----|--------------------------------|----|------------------------|
| 50 ASPHALTIC CONCRETE PAVEMENT | OR | 50 ASPHALTIC CONCRETE PAVEMENT | OR | 110 FULL DEPTH ASPHALT |
| 90 SAND ASPHALT BASE | | 250 GRANULAR BASE COURSE | | |

RESIDENTIAL ZONE

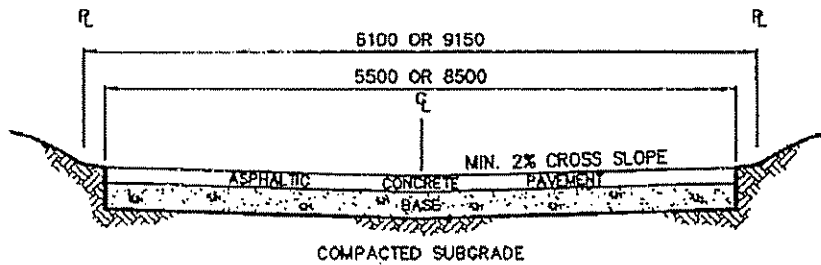

- PAVEMENT STRUCTURES**
- | | | |
|--------------------------------|--|--|
| 50 ASPHALTIC CONCRETE PAVEMENT | | |
| 130 SAND ASPHALT BASE | | |
| OR | | |
| 40 ASPHALTIC CONCRETE PAVEMENT | | |
| 140 SOIL CEMENT BASE | | |
| OR | | |
| 50 ASPHALTIC CONCRETE PAVEMENT | | |
| 350 GRANULAR BASE COURSE | | |
| OR | | |
| 140 FULL DEPTH ASPHALT | | |

BUSINESS OR INDUSTRIAL ZONE

NOTES:

1. ALL DIMENSIONS ARE IN MILLIMETRES UNLESS OTHERWISE NOTED.
2. IF PAVED PARKING LOT ABUTTS ALLEY THEN EXTEND ALLEY PAVEMENT TO PROPERTY LINE .
3. GRADE LIMITS 0.6% - 8.0%

CITY OF MOOSE JAW
ENGINEERS DEPARTMENT

ALLEY PAVEMENT STRUCTURES

DRAWN N/A	DATE MAR. / 08	DWG. NO.
R. JOHNSON CITY ENGINEER	SCALE N.T.S.	R-2B

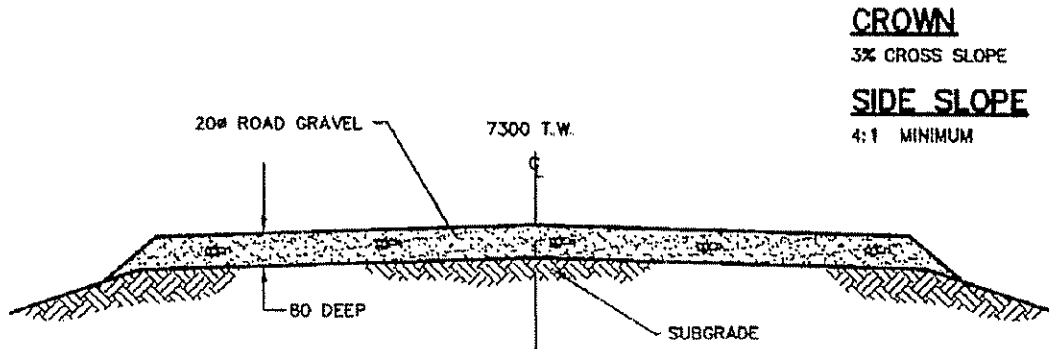

TYPICAL CROSS SECTION

NOTE:

1. ALL DIMENSIONS ARE IN MILLIMETRES UNLESS OTHERWISE NOTED.

CITY OF MOOSE JAW
ENGINEERS DEPARTMENT

GRADED AND GRAVELLED
ROAD RURAL AREA

DRAWN N/A	DATE MAR. / 08	DWG. NO.
R. JOHNSON CITY ENGINEER	SCALE N.T.S.	R-2C

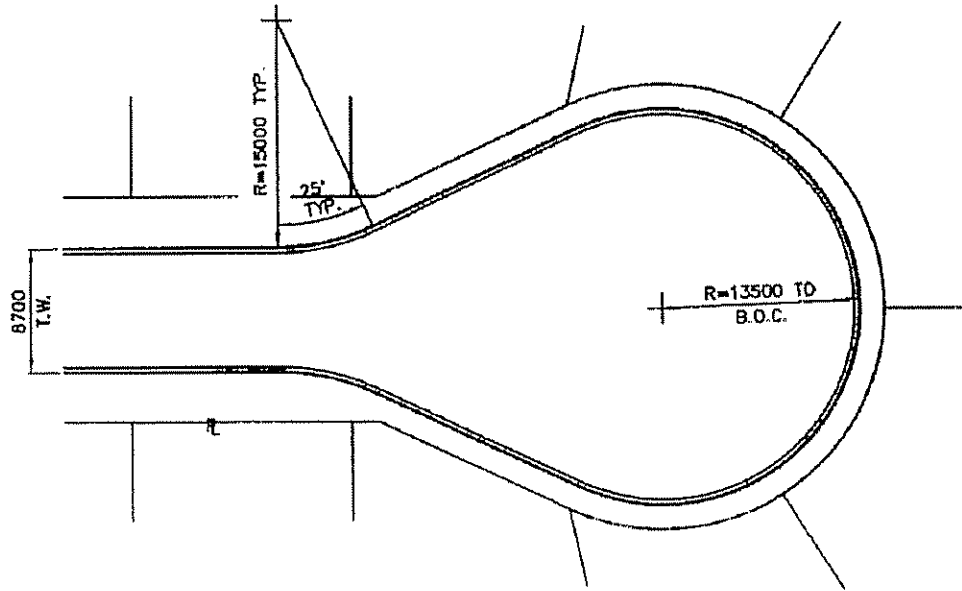

NOTE:

1. ALL DIMENSIONS ARE IN MILLIMETRES UNLESS OTHERWISE NOTED.

CITY OF MOOSE JAW
ENGINEERS DEPARTMENT

TYPICAL CUL-DE-SAC

DRAWN N/A	DATE MAR. / 08	DWG NO.
R. JOHNSON CITY ENGINEER	SCALE N.T.S.	R-2D

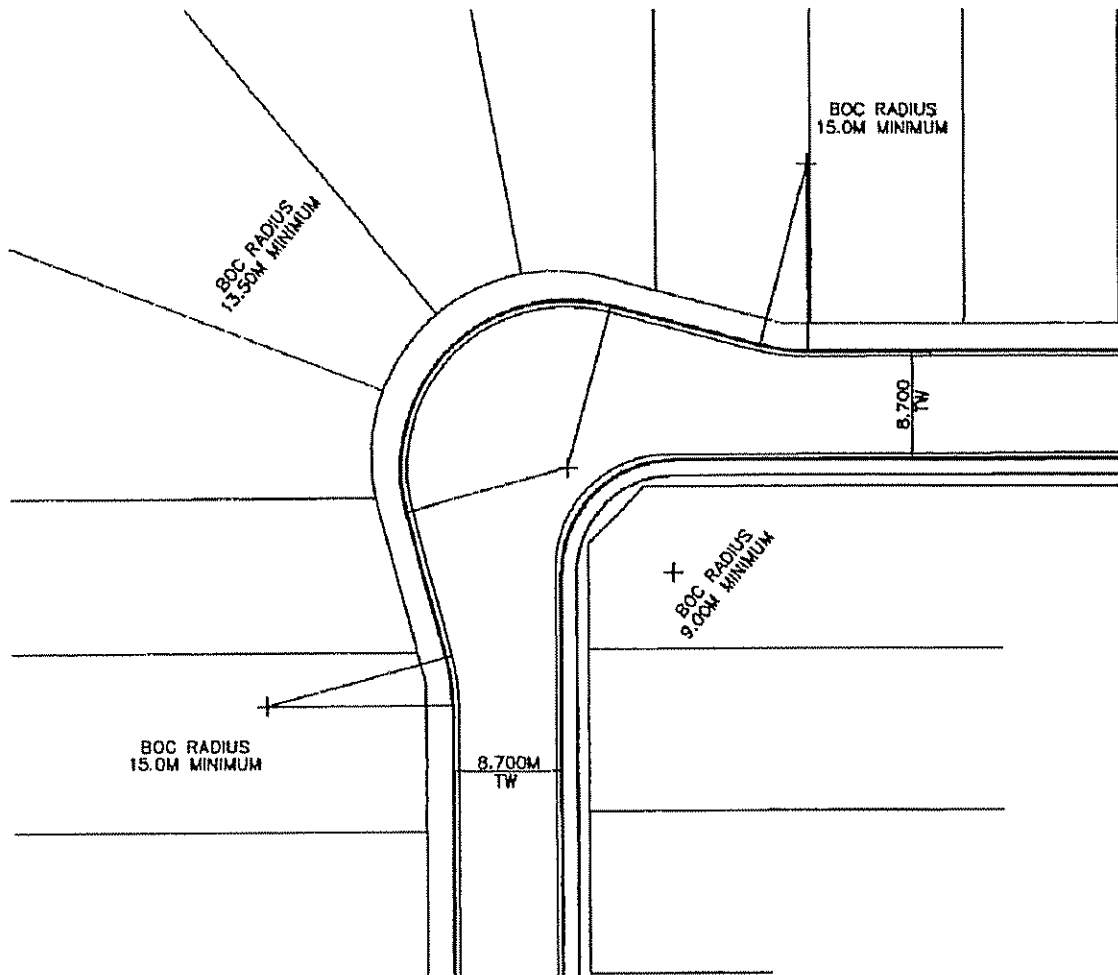

CITY OF MOOSE JAW
ENGINEERS DEPARTMENT

TYPICAL CRESCENT CORNER

DRAWN N/A	DATE MAR. / 08	DWG. NO.
R. JOHNSON CITY ENGINEER	SCALE N.T.S.	R-2E

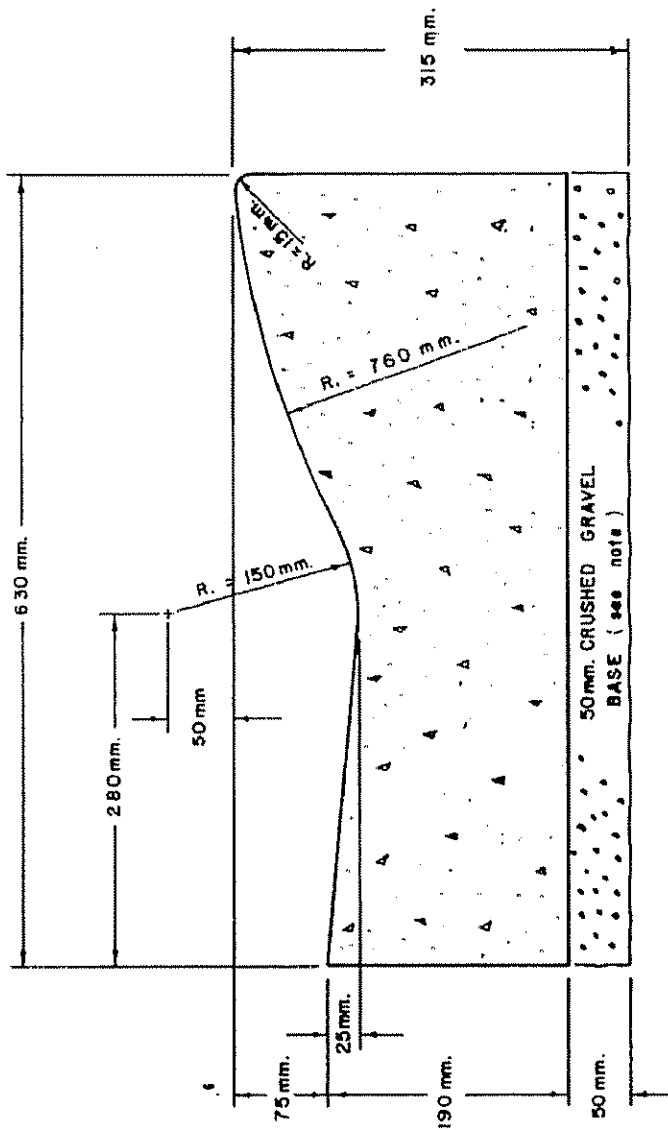

NOTE:

SEE SPECIFICATIONS SEC. 112.2
REGARDING GRAVEL CUSHION

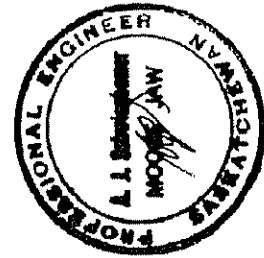

CITY OF MOOSE JAW
ENGINEERS DEPARTMENT

630mm
ROLLED
CURB & GUTTER

DRAWN J.C. NEUFELD	DATE FEB. 1/78	DWG. NO.
A.J. SCHINGHAMER CITY ENGINEER	SCALE N.T.S.	R-3A

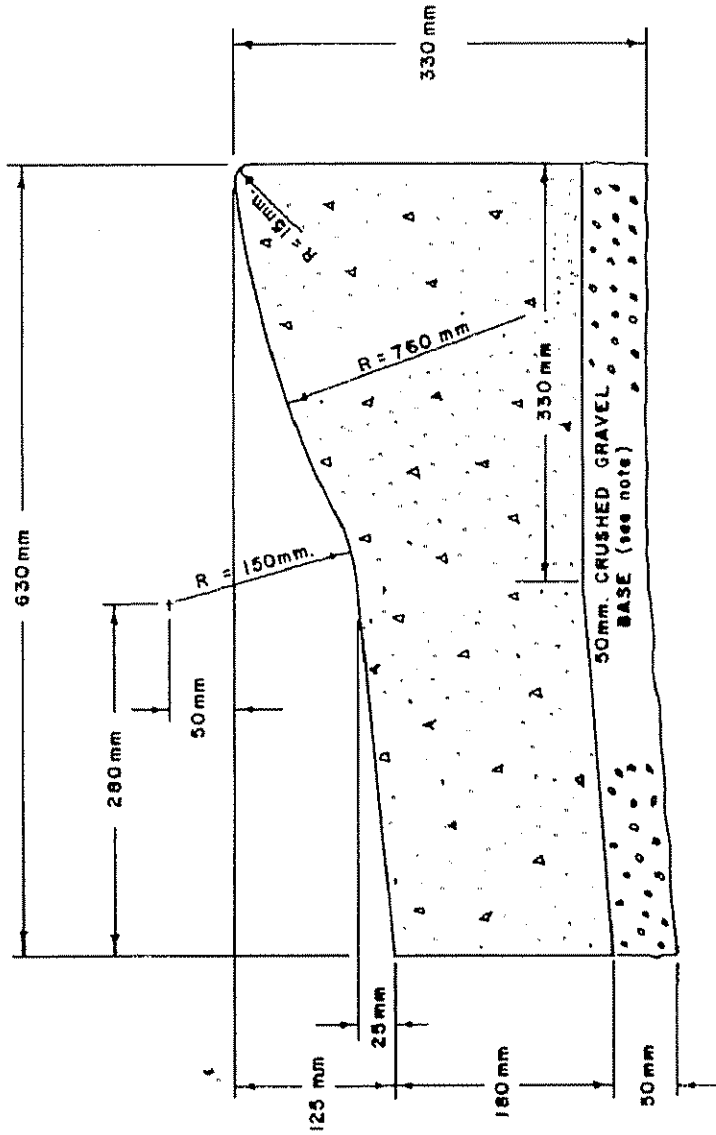

NOTE:
 SEE SPECIFICATIONS SEC. 112.2
 REGARDING GRAVEL CUSHION

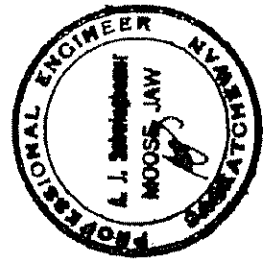

CITY OF MOOSE JAW
 ENGINEERS DEPARTMENT

630mm
 ROLLED
 CURB & REVERSE GUTTER

DRAWN B.L. JOHNSON	DATE MAY 12/83	DWG. NO.
A.J. SCHWINGHAMER CITY ENGINEER	SCALE N.T.S.	R-3B

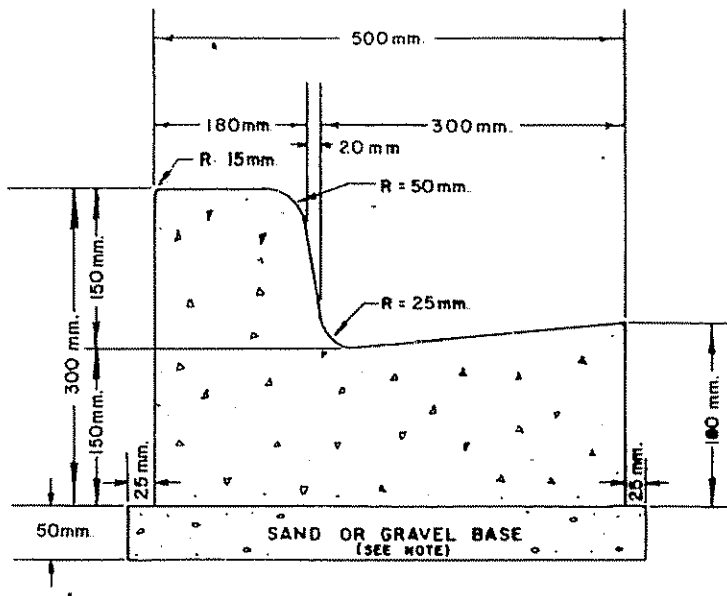

CROSS SECTION OF CURB & GUTTER

NOT TO SCALE

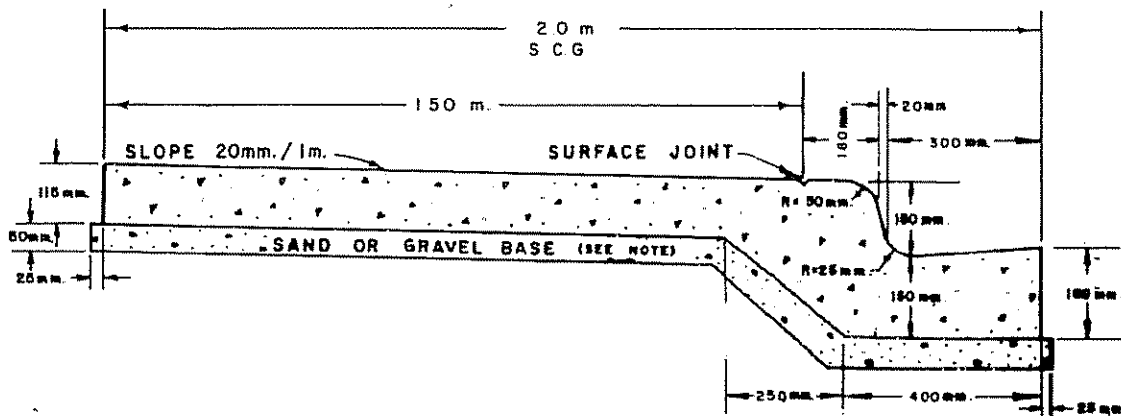

CROSS SECTION OF COMBINED SIDEWALK CURB & GUTTER

NOT TO SCALE

NOTE:

EXPANSION JOINTS TO BE OF A NON-EXTRUDING TYPE AT 6m. INTERVALS OR AS REQUIRED BY THE ENGINEER

SEE SPECIFICATIONS SEC. 112.2 REGARDING GRAVEL CUSHION

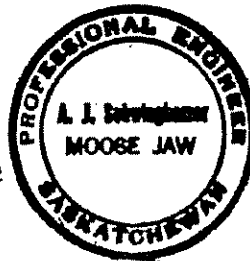

CITY OF MOOSE JAW
ENGINEERS DEPARTMENT

TYPE 'A'
COMBINED SIDEWALK
CURB & GUTTER

DRAWN M. MANDRYK	DATE FEB.22 1978	DWG. NO.
A.J. SCHWINGHAMER CITY ENGINEER	SCALE N.T.S.	R-4A

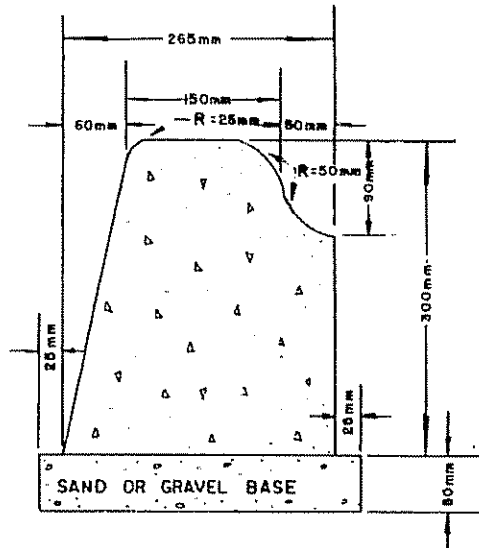

CROSS SECTION OF CURB & GUTTER

SCALE N.T.S.

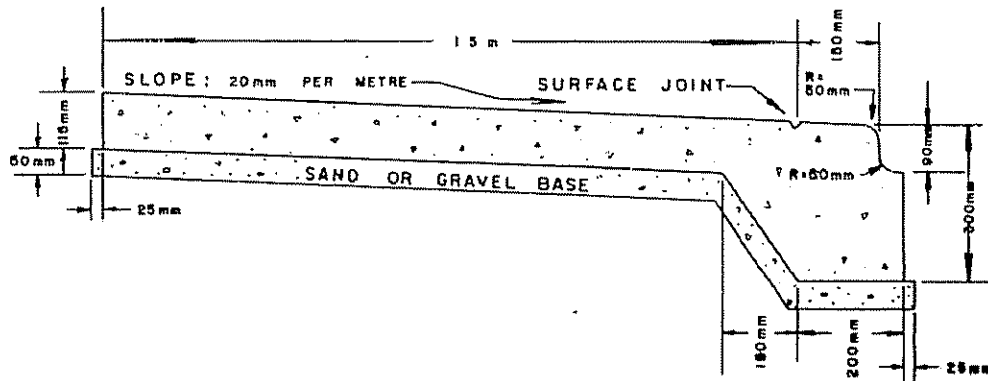

CROSS SECTION OF COMBINED SIDEWALK CURB & GUTTER

SCALE N.T.S.

NOTE:
EXPANSION JOINTS TO BE OF A
NON-EXTRUDING TYPE AT 6m
INTERVALS



CITY OF MOOSE JAW
ENGINEERS DEPARTMENT

TYPE 'B'
COMBINED SIDEWALK
CURB

DRAWN B.L. JOHNSON	DATE FEB. 8/80	DWG. NO.
A.J. SCHWINGHAMER CITY ENGINEER	SCALE N.T.S.	R-4B

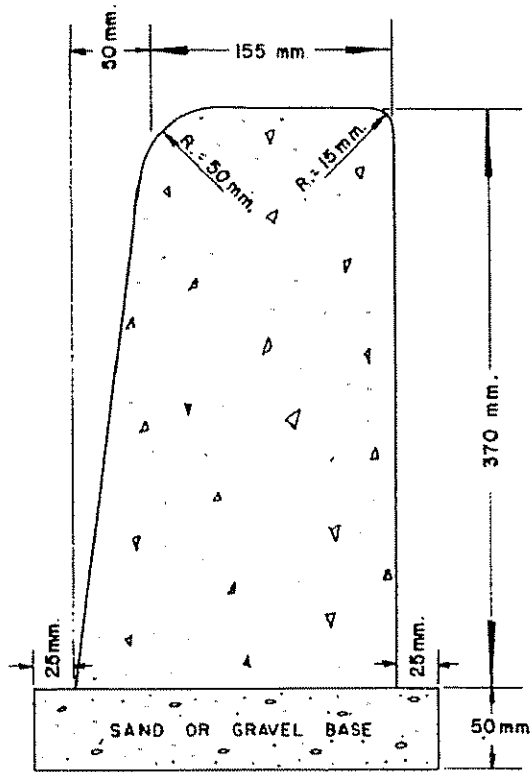

CROSS SECTION OF MEDIAN CURB

NOT TO SCALE

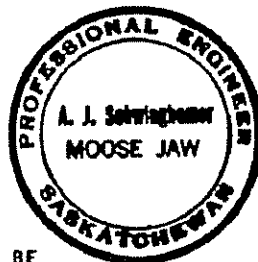

NOTE

EXPANSION JOINTS TO BE
13 mm AT 6.096 INTERVALS.
EXPANSION JOINTS TO BE
APPROVED ASPHALT IMPREGNATED
FIBRE BOARD.

CITY OF MOOSE JAW
ENGINEERS DEPARTMENT

MEDIAN CURB

DRAWN S. SHUMAY	DATE FEB. 15/78	DWG. NO.
A.J. SCHWINGHAMER CITY ENGINEER	SCALE N.T.S.	R-5A

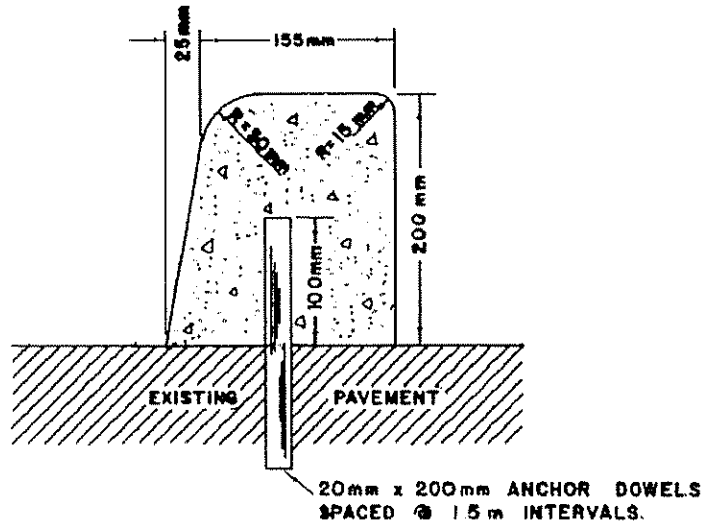

CROSS SECTION OF MEDIAN CURB

NOTE:
EXPANSION JOINTS TO BE 13 mm
AT 6 m INTERVALS. EXPANSION JOINTS
TO BE APPROVED ASPHALT IMPREGNATED
FIBRE BOARD.



CITY OF MOOSE JAW
ENGINEERS DEPARTMENT

200mm MEDIAN CURB

DRAWN L.G. SYDIAHA	DATE JUL 20/98	DWG. NO.
W.D.C. WANDZURA CITY ENGINEER	SCALE N.T.S.	R-5C

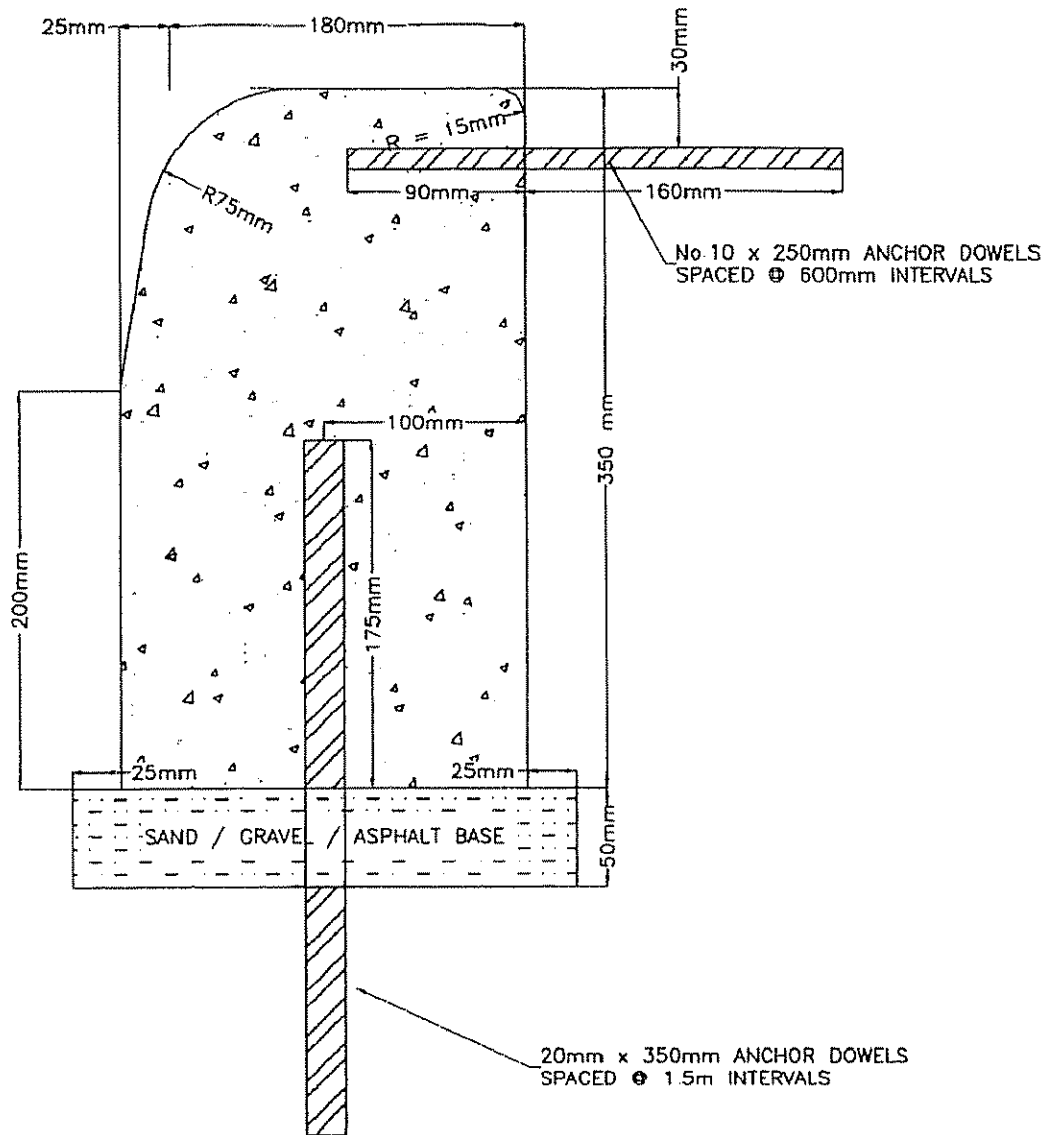

CROSS SECTION OF MEDIAN CURB

NOT TO SCALE

NOTE:
EXPANSION JOINTS TO BE OF A NON-EXTRUDING
TYPE AT 3m INTERVALS OR AS REQUIRED BY THE ENGINEER.
THE EXPANSION JOINTS ARE TO BE 13mm WIDE BY
32mm DEEP.

APPROVED ASPHALT IMPREGNATED FIBRE BOARD TO BE
PLACED IN CONTINUOUS EXPANSION JOINTS AT 15m
INTERVALS.

CITY OF MOOSE JAW
ENGINEERS DEPARTMENT

MEDIAN CURB

DRAWN L.G. SYDIAHA	DATE MARCH /99	DWG. NO.
RYAN JOHNSON CITY ENGINEER	SCALE N.T.S.	R-5D

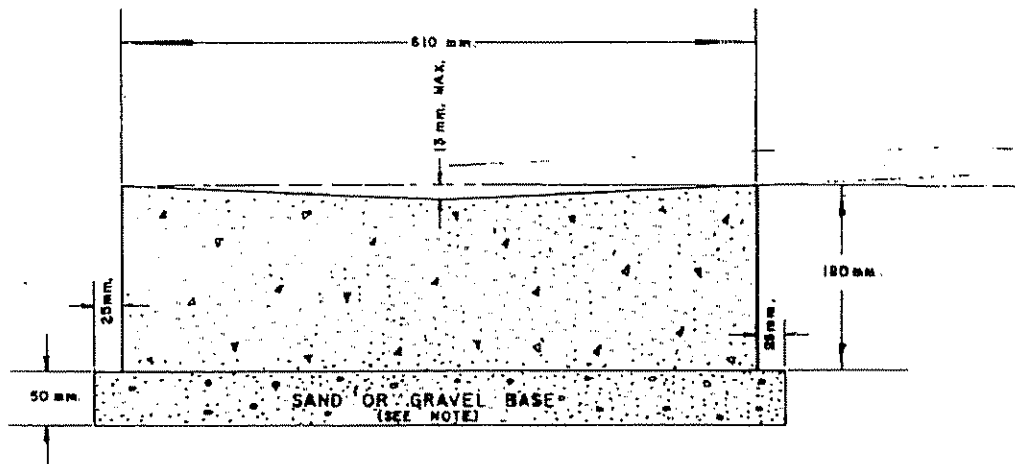

CROSS SECTION OF CHANNEL

NOT TO SCALE

NOTE:
 SEE SPECIFICATIONS SEC 112.2
 REGARDING GRAVEL CUSHION



CITY OF MOOSE JAW
 ENGINEERS DEPARTMENT

CONCRETE DRAINAGE CHANNEL

DRAWN S. SHUMAY	DATE FEB. 15/78	DWG. NO.
A.J. SCHWINCHAMER CITY ENGINEER	SCALE N.T.S.	R-6A

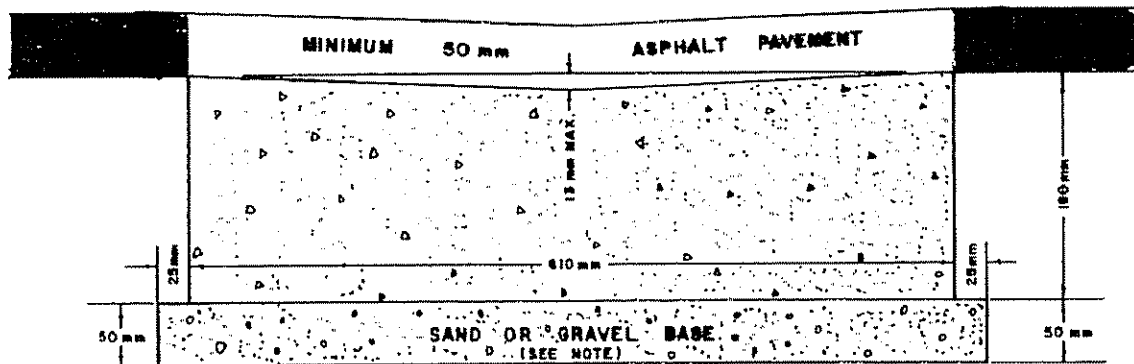

CROSS SECTION OF CHANNEL

NOTE:
SEE SPECIFICATION 112.2
REGARDING GRAVEL CUSHION.



CITY OF MOOSE JAW
ENGINEERS DEPARTMENT

ASPHALT PAVED
CONCRETE DRAINAGE CHANNEL

DRAWN L.G. SYDIAHA	DATE APR. 24/84	DWG. NO.
A.J. SCHWINGHAMER CITY ENGINEER	SCALE N.T.S.	R-6B

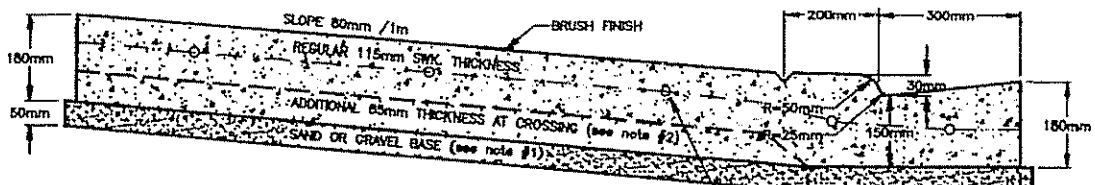

PRIVATE DRIVEWAY CROSSING

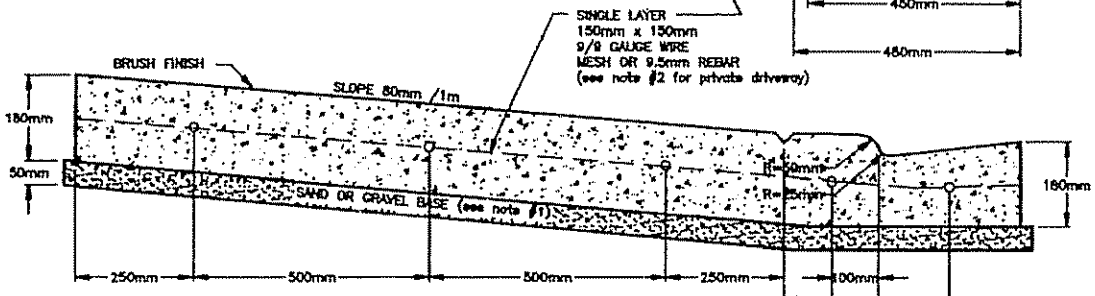

COMMERCIAL DRIVEWAY CROSSING

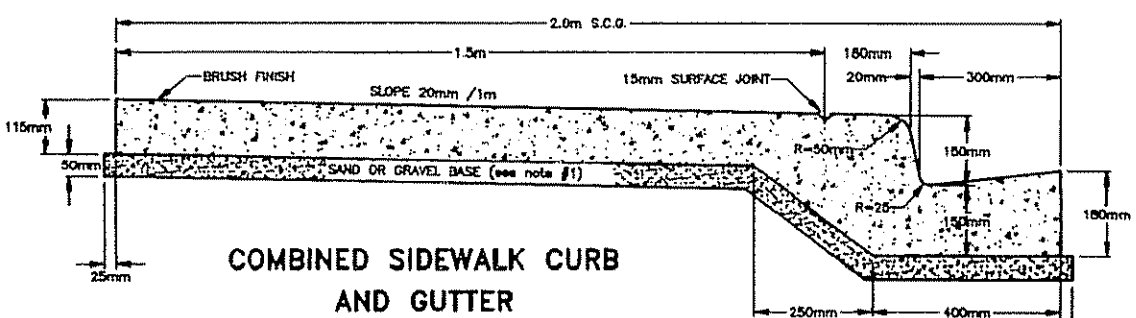

COMBINED SIDEWALK CURB AND GUTTER

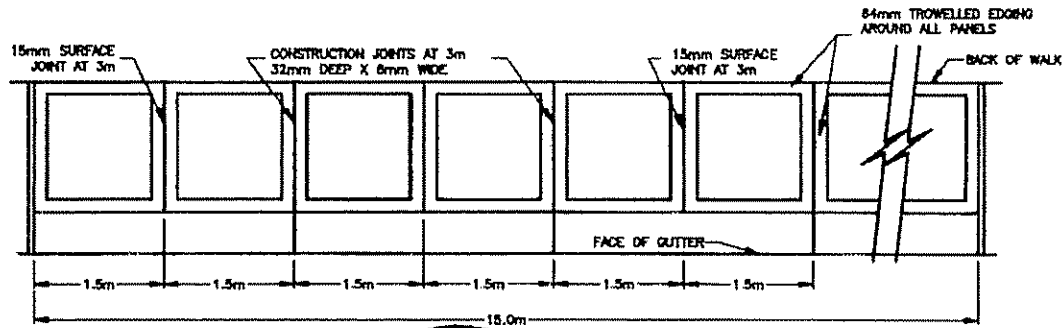

PLAN VIEW

- NOTE:**
- 1) SEE SPECIFICATIONS SEC. 112.2 REGARDING GRAVEL CUSHION.
 - 2) FOR PRIVATE DRIVEWAY CROSSINGS ONLY ADDITIONAL 65mm THICKNESS OF CONCRETE MAY BE SUBSTITUTED WITH SINGLE LAYER OF 150mm X 150mm 9/8 GAUGE WIRE OR 3 ROWS OF 9.5mm REBAR PLACED AS SHOWN ABOVE, THE FULL LENGTH OF THE CROSSING.
 - 3) NO EXPANSION JOINTS IN CROSSINGS EXCEPT IF REQUIRED BY ENGINEER.

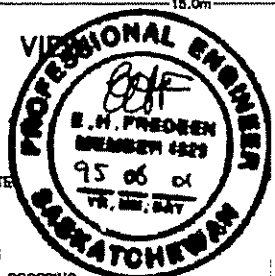

CITY OF MOOSE JAW
ENGINEERS DEPARTMENT

TYPE 'A'
COMBINED SIDEWALK
CURB & GUTTER CROSSING

DRAWN LISA HOBERG	DATE MAY 9, 1995	DWG. NO.
E.H. FREDEEN CITY ENGINEER	SCALE N.T.S.	R-7A

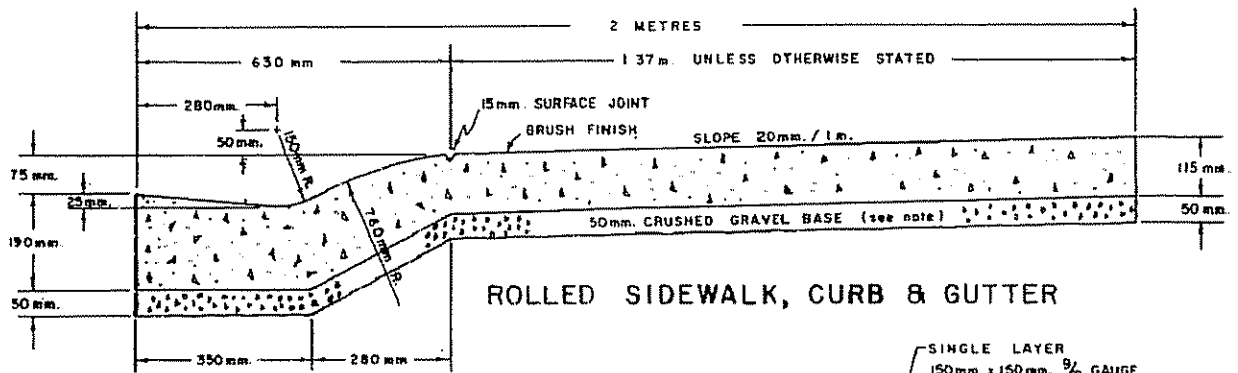

ROLLED SIDEWALK, CURB & GUTTER

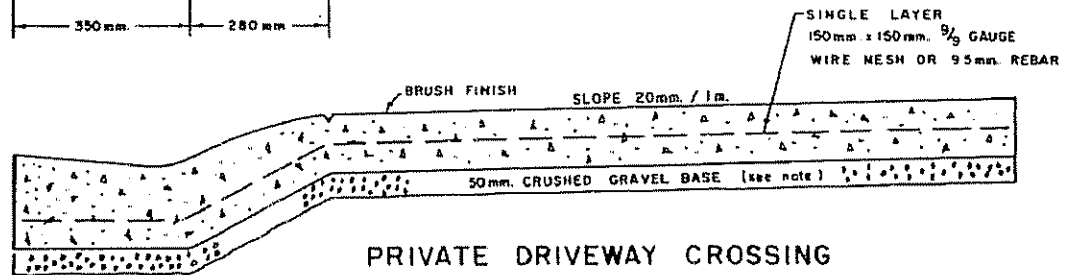

PRIVATE DRIVEWAY CROSSING

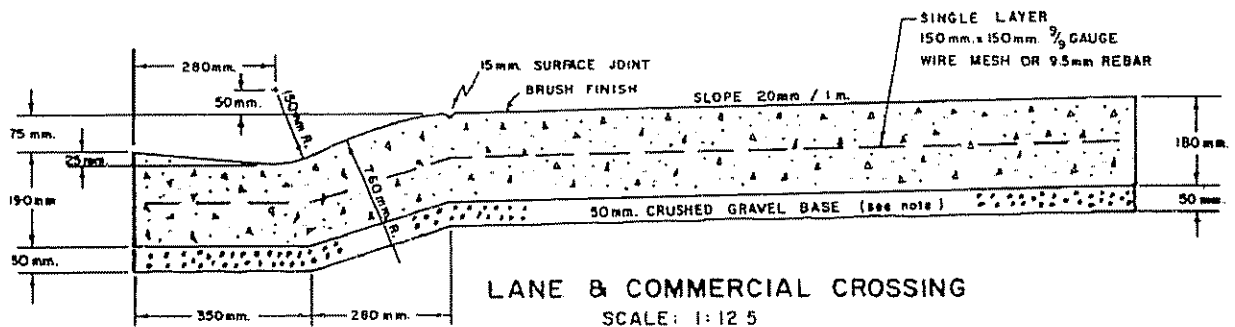

LANE & COMMERCIAL CROSSING
SCALE: 1:12.5

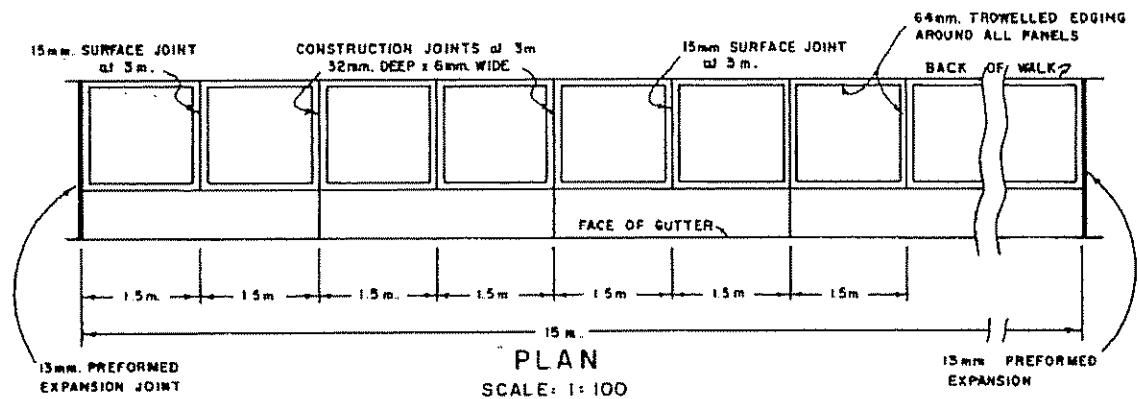

PLAN
SCALE: 1:100

NOTE:
NO EXPANSION JOINTS IN CROSSINGS
EXCEPT IF REQUIRED BY ENGINEER
SEE SPECIFICATIONS SEC. 112.2
REGARDING GRAVEL CUSHION

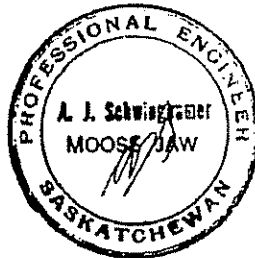

CITY OF MOOSE JAW
ENGINEERS DEPARTMENT

2 METER
ROLLED
SIDEWALK CURB & GUTTER

DRAWN J.C. NEUFELD	DATE JAN. 31/78	DWG. NO.
A.J. SCHWINGHAMER CITY ENGINEER	SCALE N.T.S.	R-7B

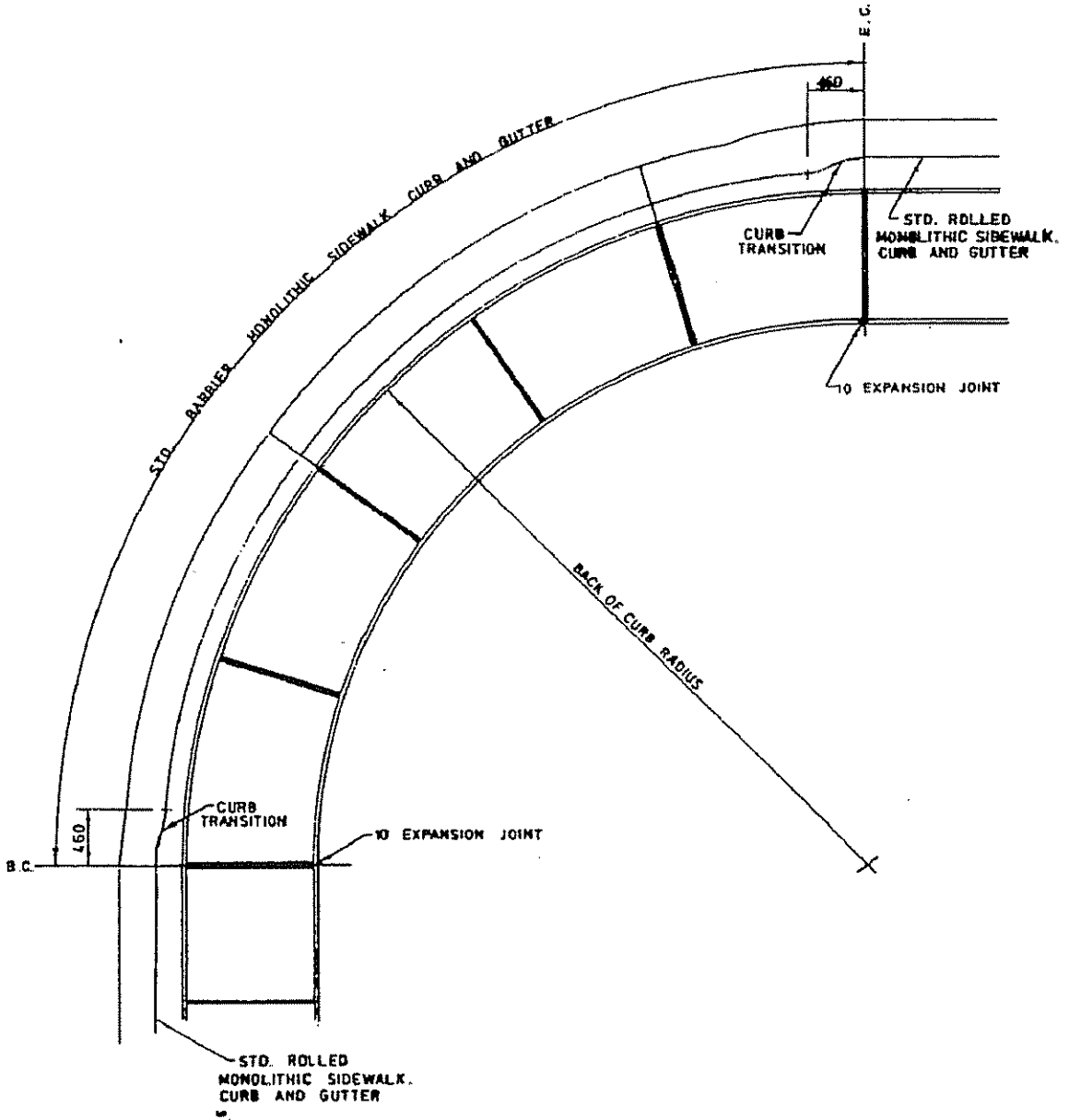

NOTES:
 UNITS SHOWN ARE MILLIMETERS
 UNLESS OTHERWISE NOTED



CITY OF MOOSE JAW
 ENGINEERS DEPARTMENT

CORNER TRANSITION FROM ROLLED
 CURB AND GUTTER
 TO BARRIER CURB AND GUTTER

DRAWN L.G. SYDIAHA	DATE MAR. 12/81	DWG. NO.
A.J. SCHWINGHAMER CITY ENGINEER	SCALE N.T.S.	R-7C

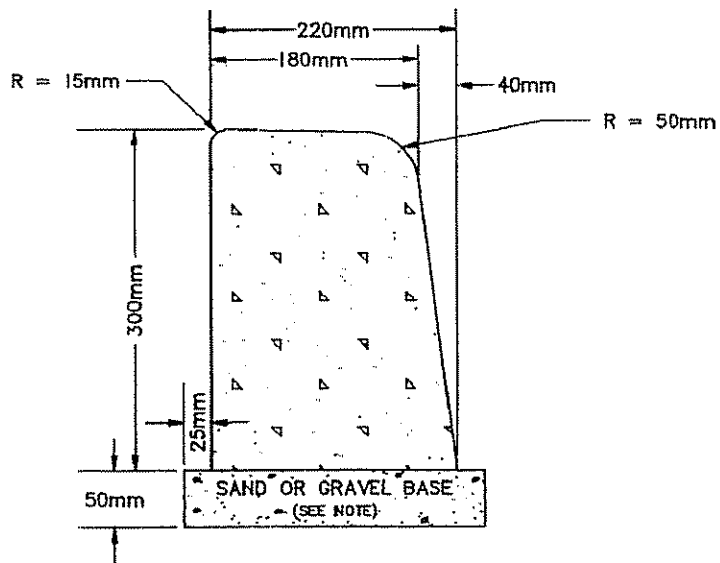

CROSS SECTION OF CURB
NOT TO SCALE

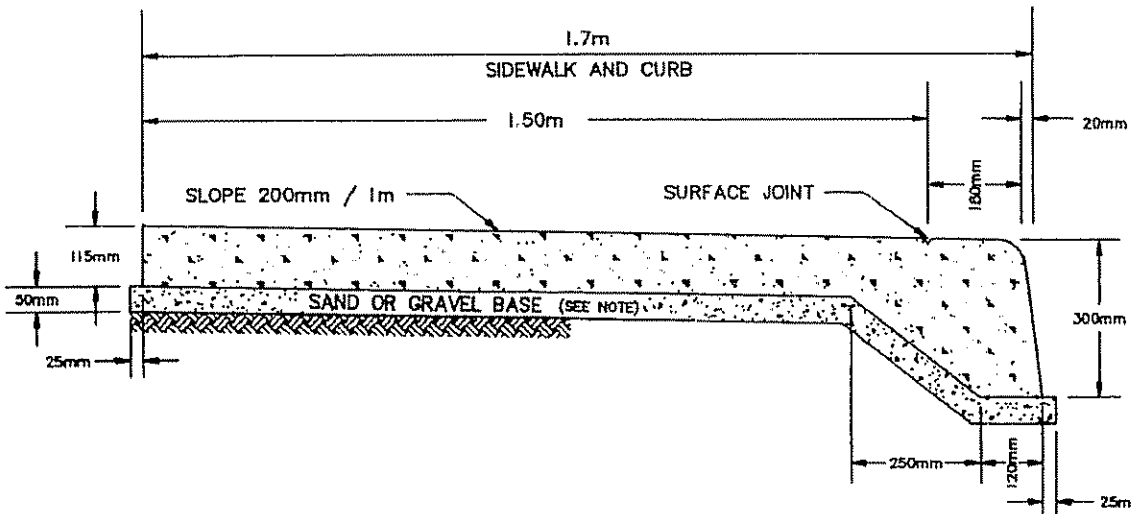

CROSS SECTION OF COMBINED SIDEWALK & CURB
NOT TO SCALE

NOTE:

EXPANSION JOINTS TO BE OF A NON-EXTRUDING TYPE AT 8m. INTERVALS OR AS REQUIRED BY THE ENGINEER.

SEE SPECIFICATIONS SEC. 112.2 REGARDING GRAVEL CUSHION



CITY OF MOOSE JAW
ENGINEERS DEPARTMENT

TYPE 'A'
COMBINED SIDEWALK & CURB

DRAWN G. GASKIN	DATE AUG. 16/91	DWG. NO.
A. J. SCHWINGHAMER CITY ENGINEER	SCALE N.T.S.	R-7D

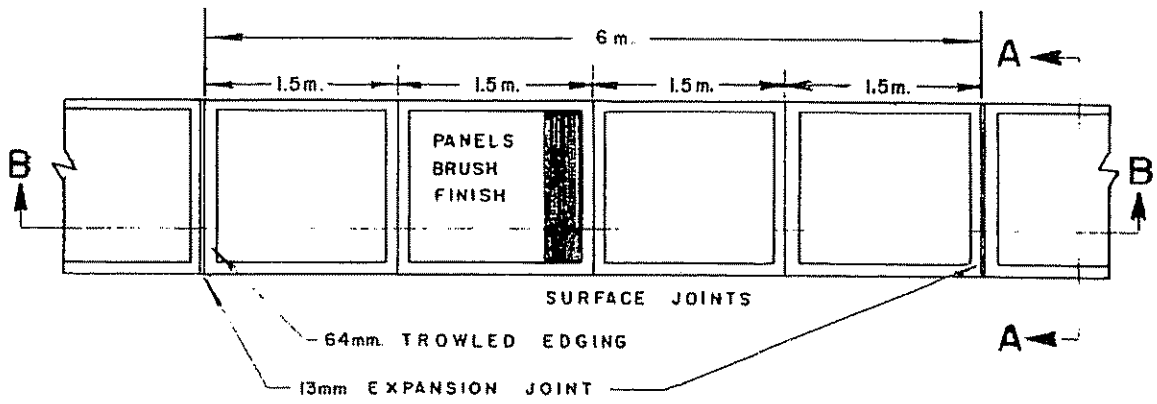

CONCRETE WALK PLAN VIEW

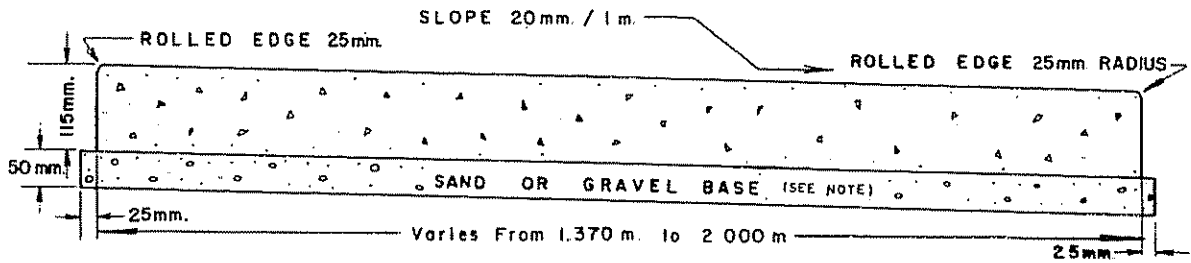

CONCRETE WALK CROSS SECTION 'A'-A

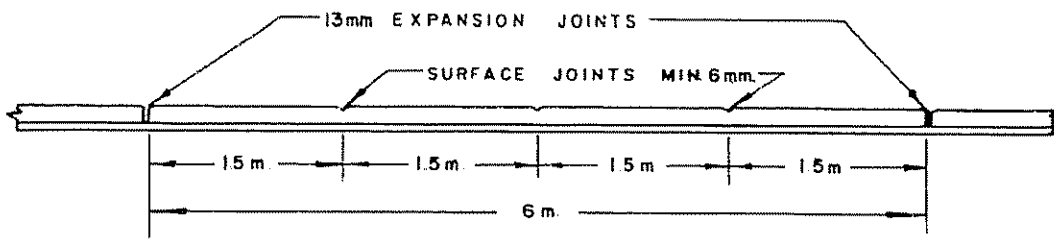

CONCRETE WALK LONGITUDINAL SECTION 'B'-B'

NOTE
 EXPANSION JOINTS TO BE OF A
 NON-EXTRUDING TYPE AT 6m
 INTERVALS OR AS REQUIRED
 BY THE ENGINEER
 SEE SPECIFICATIONS SEC. 112.2
 REGARDING GRAVEL CUSHION

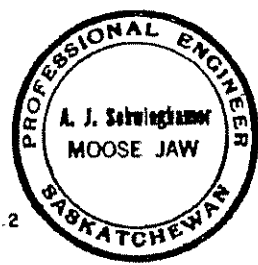

CITY OF MOOSE JAW
 ENGINEERS DEPARTMENT

TYPE 'A'
 CONCRETE SIDEWALK

DRAWN M. MANDRYK	DATE FEB.22 1978	DWG. NO.
A.J. SCHWINGHAMER CITY ENGINEER	SCALE N.T.S.	R-8

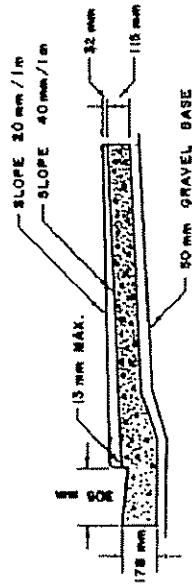
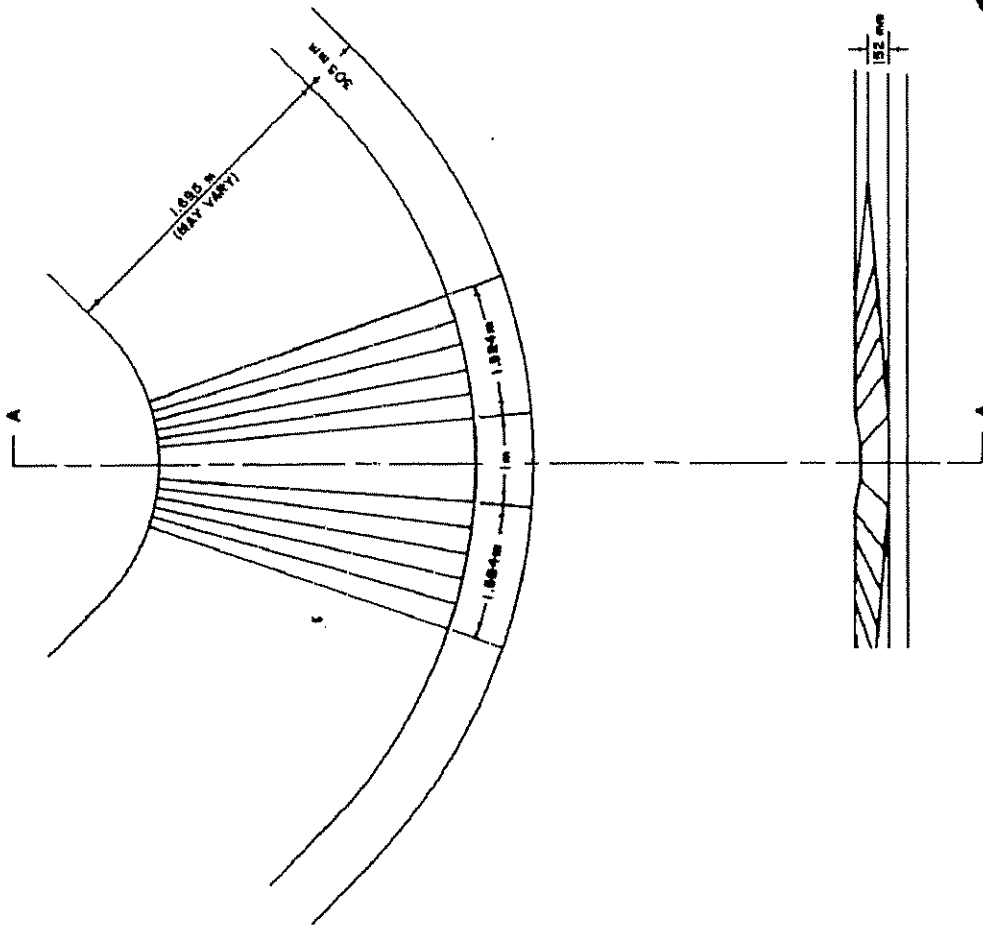

X - SECTION A - A

CITY OF MOOSE JAW
ENGINEERS DEPARTMENT

PARAPLEGIC RAMP

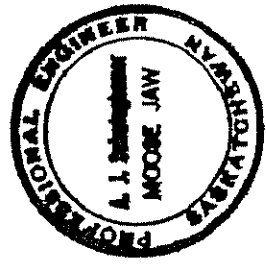

DRAWN L.G. SYDIAHA	DATE MAY 4/90	DWG. NO.
A.J. SCHMINCHAMER CITY ENGINEER	SCALE N.T.S.	R-9

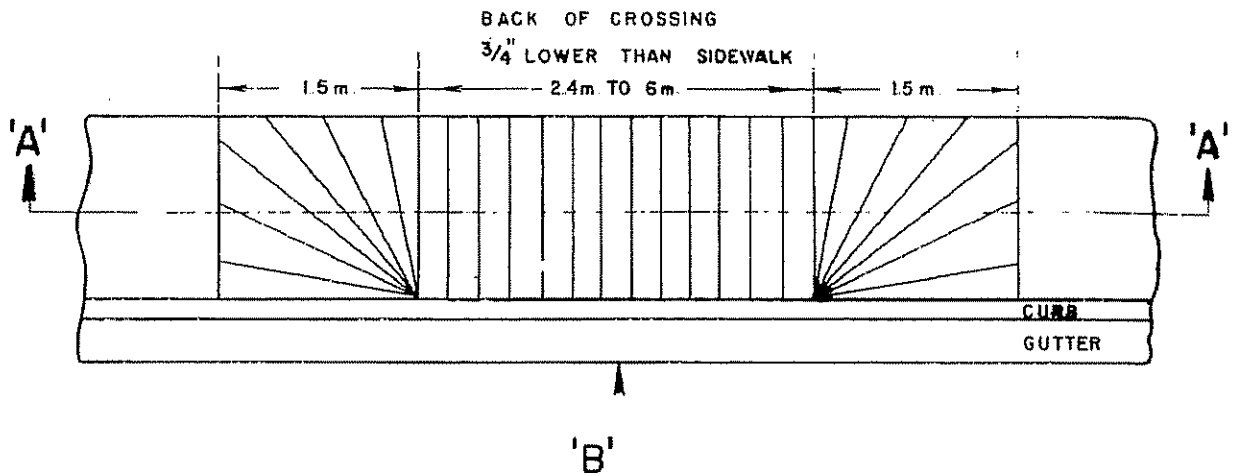

PLAN VIEW

NOT TO SCALE

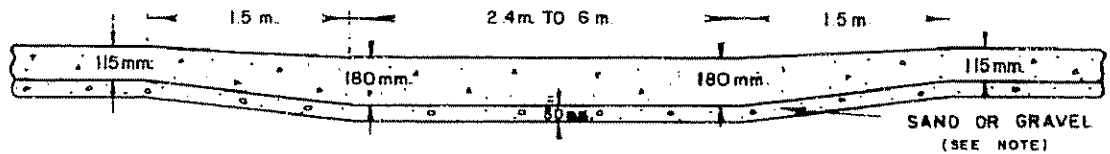

LONGITUDINAL SECTION 'A' 'A'

NOT TO SCALE

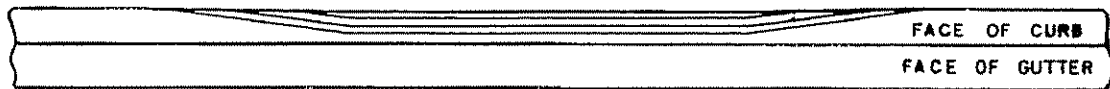

VIEW ON ARROW 'B'
LONGITUDINAL ELEVATION

(CURB SIDE)
NOT TO SCALE

NOTES

1. NO EXPANSION JOINTS IN CROSSING EXCEPT IF IN EXCESS OF 6m. OR AS REQUIRED BY THE ENGINEER.
2. MAX. WIDTH OF COMMERCIAL CROSSING IS 9m. NOT 6m. AS SHOWN ABOVE
3. SEE SPECIFICATIONS SEC. 112.2 REGARDING GRAVEL CUSHION



CITY OF MOOSE JAW
ENGINEERS DEPARTMENT

TYPE 'A'
COMBINED SIDEWALK
CURB & GUTTER CROSSING

DRAWN M. MANDRYK

DATE FEB. 22, 1978

DWG. NO.

A. J. SCHWINGHAMER
CITY ENGINEER

SCALE N.T.S.

R-10A

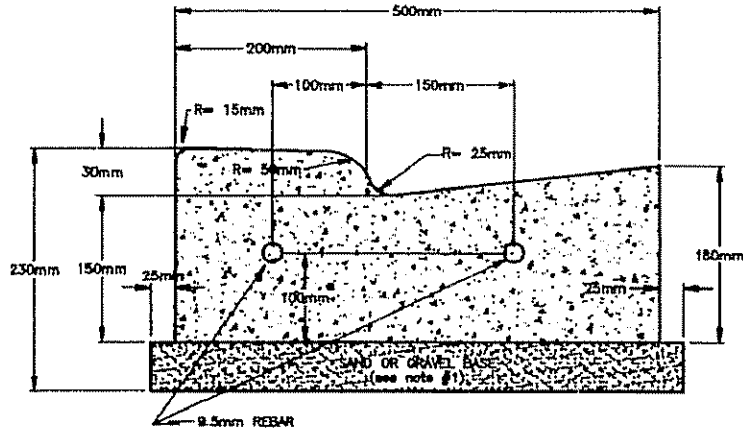

COMMERCIAL CURB AND GUTTER CROSSING

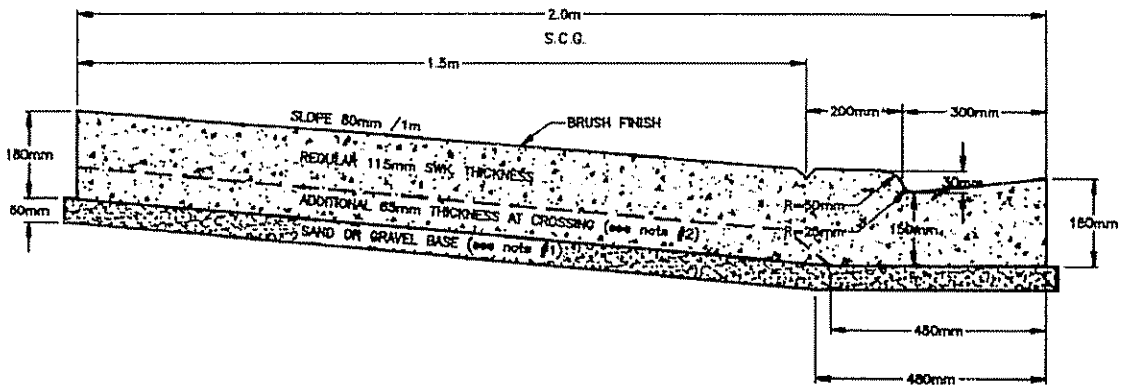

**COMBINED SIDEWALK, CURB AND GUTTER
PRIVATE DRIVEWAY CROSSING**

NOTE:

- 1) SEE SPECIFICATIONS SEC. 112.2 REGARDING GRAVEL CUSHION.
- 2) FOR PRIVATE DRIVEWAY CROSSINGS ONLY ADDITIONAL 65mm THICKNESS OF CONCRETE MAY BE SUBSTITUTED WITH SINGLE LAYER OF 150mm X 150mm 9/9 GAUGE WIRE OR 3 ROWS OF 9.5mm REBAR PLACED AS SHOWN ABOVE, THE FULL LENGTH OF THE CROSSING.
- 3) NO EXPANSION JOINTS IN CROSSINGS EXCEPT IF REQUIRED BY ENGINEER.



CITY OF MOOSE JAW
ENGINEERS DEPARTMENT

TYPE 'A'
COMBINED SIDEWALK
CURB & GUTTER CROSSING

DRAWN LISA HOBERG

DATE MAY 9, 1995

DWG. NO.

E.H. FREDEEN
CITY ENGINEER

SCALE N.T.S.

R-10B

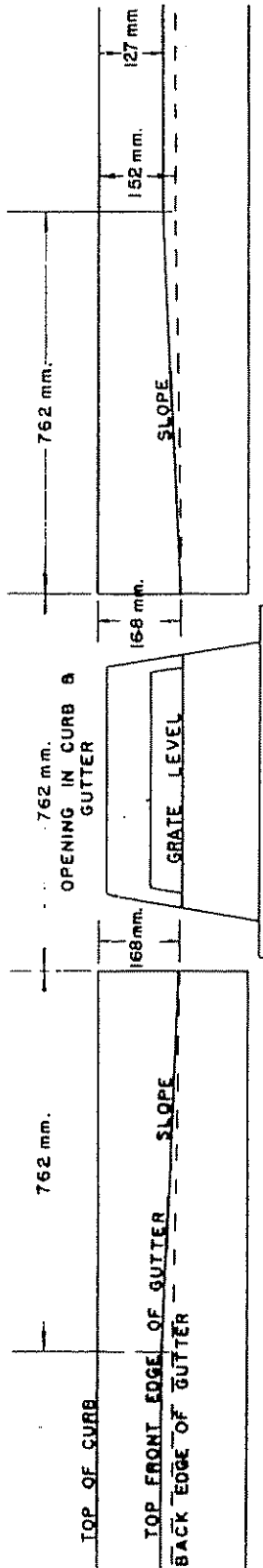

CITY OF MOOSE JAW
ENGINEERS DEPARTMENT

GUTTER DETAIL
FOR
CATCH BASIN INSTALLATION

DRAWN M. MANDRYK	DATE FEB. 15, 1979	DWG. NO.
A.J. SCHWINGHAMER CITY ENGINEER	SCALE N.T.S.	R-11

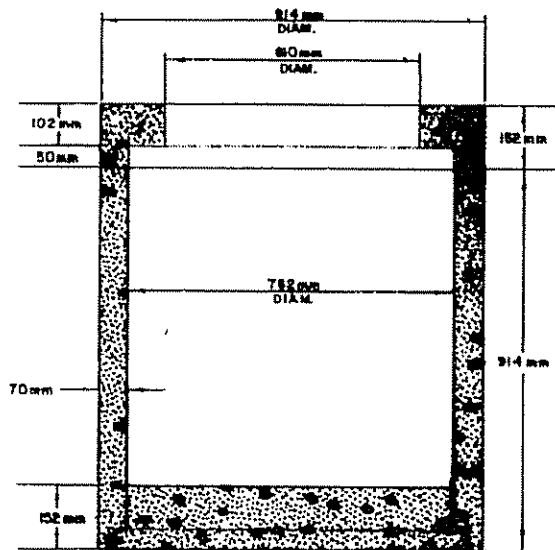

CROSS SECTION

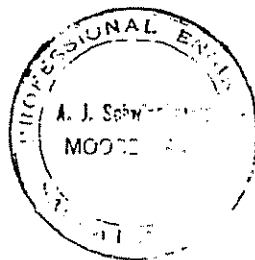

CITY OF MOOSE JAW
ENGINEERS DEPARTMENT

PRECAST CONCRETE
CATCH BASIN WELL

DRAWN L.G. SYDIAHA	DATE APR. 29/82	DWG. NO.
A.J. SCHWINGHAMER CITY ENGINEER	SCALE N.T.S.	R-12